



GEAR PUPPY

MODELS:

23230-2012 12 Volts DC

23230-2024 24 Volts DC



FEATURES:

Medium duty pumps for general purpose use.

- ISO 8846 MARINE (Ignition protection)
- Maximum viscosity 150Cs
- Inlet filter included
- Simple design means fewer wearing parts
- 24.5 lpm (6.5 US gpm) output @ 5m (16.4ft) head
- Self priming to 1.0m (3 ft)
- Ideal for water, oil and diesel transfer

GEAR PUPPY PERFORMANCE

Approximate performance for new pump, running water at 20°C with fully charged battery

TOTAL HEAD		GEAR PUPPY	
m	ft	lpm	US gpm
0	0	26	6.9
5	16.4	24.5	6.5
10	33	22.5	6.0
15	49	20	5.3
20	65	17	4.5

INSTALLATION INSTRUCTIONS:

JabSCO Gear Puppy can be mounted on any flat surface. Fit the pump in a dry, well ventilated position. If installed in a vertical position the motor must be above the pump head. Use the rubber grommets provided to minimise vibration, do not overtighten the mounting screws.

Secure 16mm ($\frac{5}{8}$ " id hose direct to the discharge ports using stainless steel hose clamps. Use spiral reinforced hose (with a smooth internal bore) that will not collapse under suction, or rigid or semi rigid pipework systems. The pipework must be compatible with the liquid being pumped. Pipe runs should be kept as straight and short as possible, avoiding rising and dipping over obstructions. Fit a filter on the inlet to prevent debris from entering the pump.

WIRING INSTRUCTIONS

Make all electrical connections in dry locations, connections in humid environments should be sealed to prevent corrosion. Protect the circuit with a correctly rated fuse or circuit breaker in the red positive (+) lead as close as possible to the power source. Connect the black motor wire to the negative (-) battery terminal. Inadequate voltage at the motor terminals when the pump is running (not less than 10% below rated voltage at full load) due to partially discharged batteries or insufficient cable size may result in blowing fuses, failure to start or poor pump performance.



WARNING: If the fuse fails repeatedly do not fit a heavier fuse or bridge the fuse terminals with silver paper or metal wire. Failure to observe this instruction may result in a fire hazard due to overheating of cables.



WARNING: Do not use any JabSCO pump for petrol, petroleum products or any products with a flash point below 37°C (98°F), explosion or death may occur.



WARNING: All marine pumps discharging overboard must be installed with the overboard discharge well above both static and heeled waterlines.



Electrical Wiring Information					
PART NUMBERS	VOLTAGE	MAXIMUM AMP DRAW	MAXIMUM FUSE SIZE	MINIMUM WIRE SIZE	MAXIMUM LENGTH BETWEEN (+) & (-) BATTERY TERMINALS
23230-2012	12 volt	12 amp	15 amp	30 / 0.25mm (1.5mm ²)	4.5m (15ft) *
23230-2024	24 volt	5 amp	7.5 amp	32 / 0.2mm (1.0mm ²)	4.5m (15ft) *

* For longer installations, fit thicker cables

DIMENSIONAL DRAWING

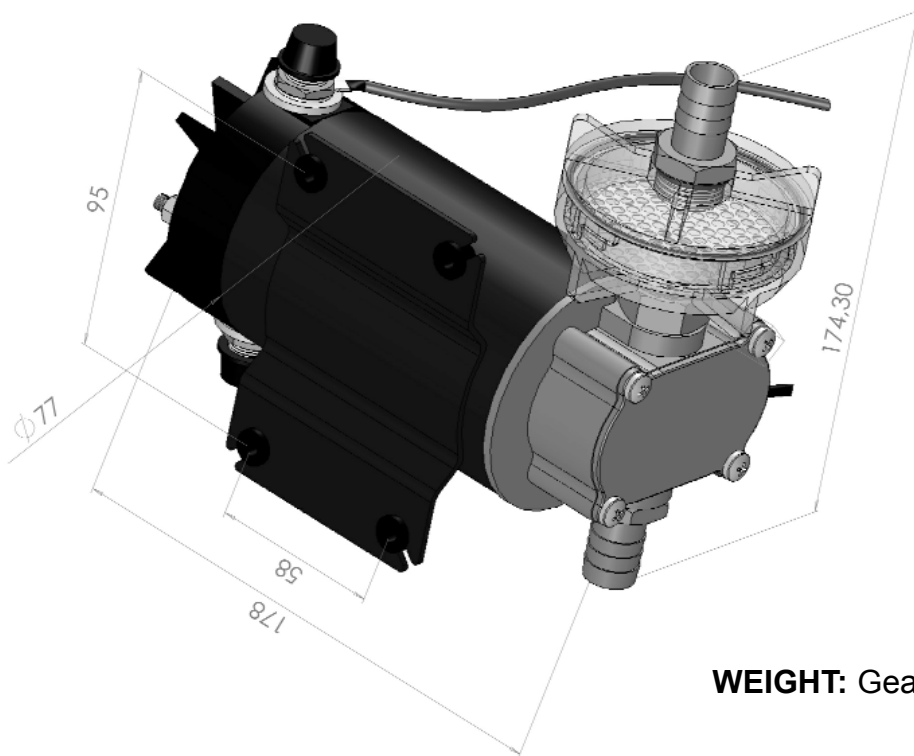

WEIGHT: Gear Puppy - 2.2kg (4.8lb)

All dimensions are in mm

Jabsco



ITT Industries

Jabsco, 1 Kondelin Road, Cape Ann Industrial Park, Gloucester, MA 01930
Tel : +1 978 281 0440 Fax : +1 978 283 2619

USA

Jabsco, Bingley Road, Hoddesdon, Hertfordshire, EN11 0BU
Tel : +44 (0) 1992 450 145 Fax : +44 (0) 1992 467 132

UK

Fluid Products Canada, 55 Royal Road, Guelph, Ontario N1H 1T1
Tel : +1 519 821 1900 Fax : +1 519 821 5316

CANADA

NHK Jabsco Co Ltd, 3-21-10, Shin - Yokohama, Kohoku-ku, Yokohama 222
Tel : +81 (0) 45 475 8906 Fax : +81 (0) 45 475 8908

JAPAN

Jabsco GmbH, Oststraße 28, 22844 Norderstedt
Tel : +49 (0) 40 53 53 73 0 Fax : +49 (0) 40 53 53 73 11

GERMANY

Warranty: All products of the company are sold and all services of the company are offered subject to the company's warranty and terms and conditions of sale, copies of which will be furnished upon request.

©Copyright 2003 ITT Industries

Discover Jabsco at www.jabsco.com

Rev 10/03 43000-0796