

SELF-PRIMING PUMP FEATURES

Body: Bronze
 Impeller: Jabsco Neoprene Compound
 Ports: Lip Type
 Ports: 3/4" NPT
 Weight: 4 lb (1.8 kg) Approx.

APPLICATION

Marine Engine Cooling
 Perkins Model 4-107 and 4-108

INSTALLATION INSTRUCTIONS

NOTICE: If installing this pump on a Perkins 4-107 or 4-108 engine, it is essential that the pump shaft is properly aligned with the driving-shaft on the engine. If the pump adaptor plate (Perkins Part No. 33154119) that the pump mounts to has been loosened, it must be realigned using a special Perkins alignment tool when it is resecured to the engine. Contact your Perkins Service Dealer to arrange the adaptor plate realignment. Failure to have the adaptor plate properly aligned prior to installing the pump can cause severe damage to the pump and/or the engine.

Before installing the pump, note the position of the tang on the engine's pump-driving shaft relative to the pump mounting studs (holes). Then use a screwdriver or thin bar inserted between the drive tabs on the pump shaft to rotate the shaft so it will align with and engage the tang on the engine's pump-drive.

Install a new gasket between the engine and pump mounting flange. Then, ensuring the engine's drive tang and the pump's drive tabs are properly engaged, position the pump against the engine. Make certain the pump alignment collar is properly seated in the registration hole on the engine so the pump mounting flange fits flush against the engine. Secure the pump with four nuts or machine screws and lock washers.

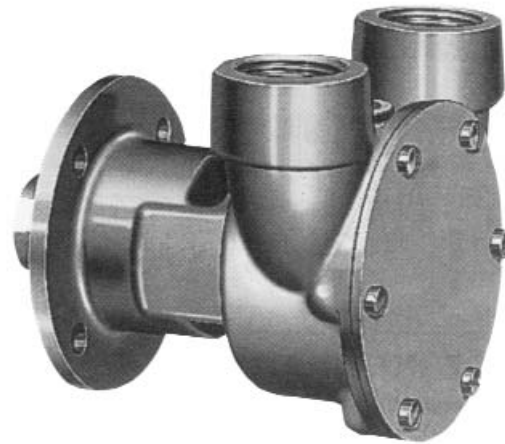
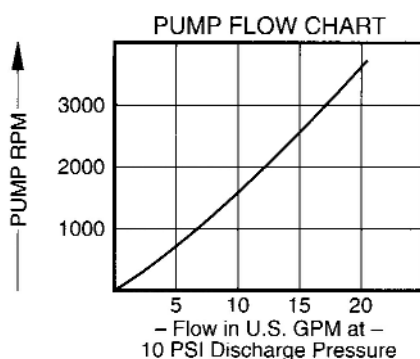

Model 3270-0001

OPERATING INSTRUCTIONS

The pump will self-prime with a lift of about three feet at low or high speeds. Before starting engine ensure the inlet plumbing, including the inlet through-hull and scoop is free of blockages or debris. The inlet seacock and any valves in the inlet plumbing must be fully open.

The water being pumped serves as a lubricant for the flexible impeller and keeps the impeller and pump cool. Therefore, do not run the pump dry for more than 30 seconds or the impeller and pump will likely be damaged.

To winterize the pump, drain the liquid from the impeller cavity by loosening the end cover screws. Lightly tap the end cover, if necessary, to break it loose from the body.

DIMENSIONAL DRAWING

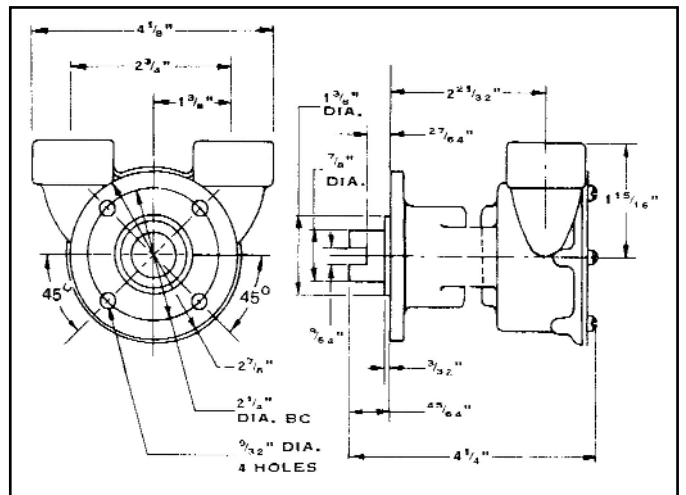

CROSS SECTION

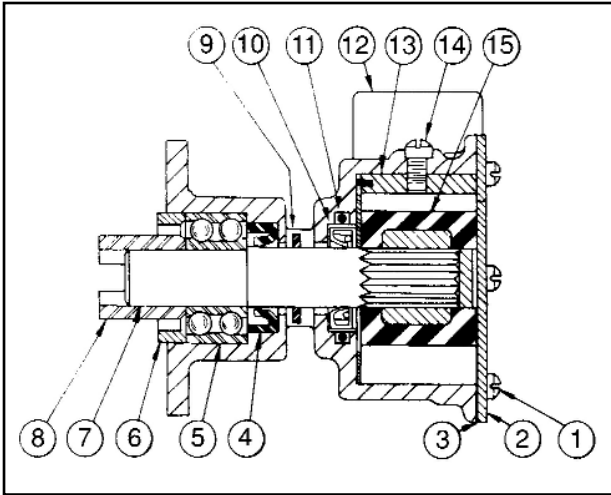

SERVICE INSTRUCTIONS

Impeller Replacement: Remove the end cover and end cover gasket. Pull the impeller out of the impeller bore by grasping the hub with a pair of water pump pliers pulling it straight out. A light coat of grease applied to the impeller bore and ends of the impeller will aid priming on initial engine start-up. Install a new impeller by pushing it into the impeller bore with a rotary motion in the direction of normal pump rotation until the impeller spline contacts the shaft. With a firm straight inward push, seat the impeller in the bottom of the impeller bore. Position a new gasket and the end cover against the pump body and secure it with the end cover screws.

Major Repair: Remove the four nuts or machine screws and lock washers, if installed, that secure the pump mounting flange to the engine and remove the pump to replace the shaft seal, bearing or the shaft assembly.

Notice: If removing the pump from a Perkins 4-107 or 4-108 engine, do not loosen the four outer nuts that secure the engine's pump adaptor plate to the timing gear cover and engine. Loosen only the four inner nuts that secure the pump mounting flange to the adaptor plate. If the outer adaptor plate nuts are loosened, the plate must be realigned before the pump can be reinstalled (see Notice: on front page).

Disassembly: Remove the end cover, gasket and impeller as described in impeller replacement instructions. With an arbor press and drift, press on the impeller end of the shaft to remove the alignment collar (Key 6) and the shaft, drive coupling and bearing subassembly. The slinger can then be removed from the space between the impeller bore end and bearing bore end of the body. Loosen the cam screw a couple of turns and tap it sharply to break cam free from the top of the impeller bore. Finish removing the cam screw and cam. Tap the pump body, impeller end down, on a soft surfaced table to shake the wearplate out of the impeller bore. From the drive end of the pump, use a drift or dowel to push the shaft seal out of the seal bore. With needle nose

PARTS LIST

Key	Description	Part Number	Quantity
1	Screw, end cover	91002-0020	6
2	End Cover	3275-0000	1
3	* Gasket	3298-0000	1
4	Seal, bearing	92700-0060	1
5	Bearing	92600-0070	1
6	Alignment Collar	3276-0000	1
7	Shaft	3277-0000	1
8	Coupling	3278-0000	1
9	Slinger	3286-0000	1
10	* Seal, shaft	92700-0060	1
11	O-ring†	92000-0210	1
12	Body	3274-0000	1
13	Cam & Waerplate Assembly	7884-0000	1
14	Cam screw	91003-0010	1
15	* Impeller	1210-0001	1
	Sevice Kit	90033-0001	

* Parts contained in Service Kit

† O-ring used only in pump model 3270-1003

pliers reach into the drive end of the pump and grasp the lip of the bearing seal to pull it from the seal bore. If the bearing, coupling or shaft are to be replaced, support the inner bearing race and with a small drift, press the shaft out of the coupling and bearing.

Clean all parts and inspect them for wear. If the bearing does not roll smoothly or had noticeable wobble between the races, it should be replaced. If the shaft has easily detected grooves worn under the lips of the seals, it should be replaced. If the cam, wearplate or endcover have easily detected grooves or wear rings, they should be replaced.

Assembly: Press the drive end of the shaft into the bearing taking care to support the inner race of the bearing. Press the drive coupling onto the shaft. Position a new bearing seal in the bearing bore with the seal lip pointed toward the drive end of the pump and push it into the seal bore. Position the slinger in the cavity between the impeller end and bearing end of the pump. Insert the shaft, bearing and coupling sub-assembly through the bearing bore and slinger until the bearing contacts the body. Taking care to press against the outer bearing race, press the shaft assembly into the pump body until it is firmly seated. Press the alignment collar into the bearing bore until it seats firmly against the bearing. This should be a tight press because it secures the bearing/shaft assembly in place.

Slide the shaft seal over the shaft with the lip pointing toward the end cover and push it firmly into the seal bore. Drop the wearplate into the impeller bore ensuring the positioning notch is centered in the cam area of the bore. Apply a small amount of non-hardening sealant to the top of the cam and place it into the impeller bore. Ensure the pin in the cam engages the notch in the wearplate and the cam is fully seated in the bore and secure it with the cam screw. Using a rotary motion, push the impeller into the impeller bore. Position a new gasket and the end cover on the body and secure them with the end cover screws.

Jabsco



ITT Industries

Jabsco, 20 Icon, Foothill Ranch, CA 92610

Tel : +1 949 609 5106

Fax : +1 949 859 1254

USA

Jabsco, Bingley Road, Hoddesdon, Hertfordshire, EN11 0BU

Tel : +44 (0) 1992 450 145

Fax : +44 (0) 1992 467 132

UK

Fluid Products Canada, 55 Royal Road, Guelph, Ontario N1H 1T1

Tel : +1 519 821 1900

Fax : +1 519 821 5316

CANADA

NHK Jabsco Co Ltd, 3-21-10, Shin - Yokohama, Kohoku-ku, Yokohama 222

Tel : +81 (0) 45 475 8906

Fax : +81 (0) 45 475 8908

JAPAN

Jabsco GmbH, Oststraße 28, 22844 Norderstedt

Tel : +49 (0) 40 53 53 73 0

Fax : +49 (0) 40 53 53 73 11

GERMANY