

GENERAL INFORMATION – STANDARD MODEL

Type	K-00	K-0	K-1	K-2	K-3	K-4	K-5	K-7	
Size in inches	3/8"	1/2"	3/4"	1"	1 1/4"	1 1/4"	1 1/2"	2"	
Weight*	kg	3.2	5.1	6.1	8.8	11.5	12.6	16	32
	Lbs	7.0	11.2	13.4	19.4	25.4	27.8	35.3	70.5
Double strokes* (per min)		80	65	60	55	50	50	45	40
	LPM	7.5	11.5	17.25	22.5	29	43.25	53.5	90
Capacity									
	GPM	1.65	2.5	3.75	5	6.5	9.5	11.75	19.8
Max Delivery	m	25	25	25	25	22	22	20	15
Head	feet	82	82	82	82	72	72	66	49
Pieces per case		30	30	25	15	10	8	6	3
	gross	117	174	174	153	136	122	117	116
Weight per case									
	net	96	153	153	132	115	101	96	95

*This data is approximate

Suction lift – 7m for all sizes

For prolonged use at depth below 3m, a foot valve should be fitted.

DIMENSIONS – STANDARD MODEL TYPE K

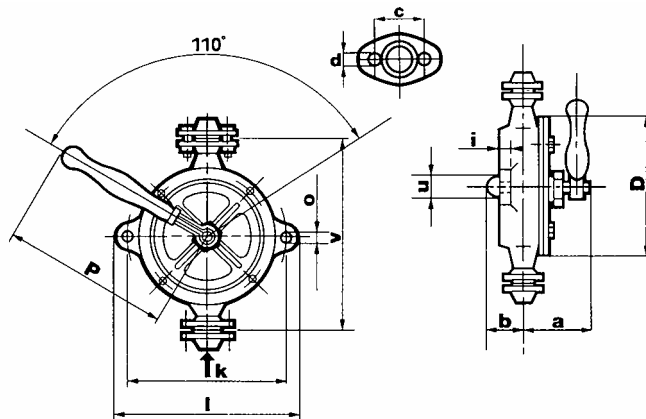

Measurements for the letter symbols can be found in the table below.

Size	K-00	K-0	K-1	K-2	K-3	K-4	K-5	K-7
D	100	135	150	170	200	220	245	288
a	90	140	140	145	170	190	200	273
b	45	55	55	60	62	74	76	72
i	7.5	10	10	10	12	12	12	15
k	98	130	150	170	200	220	240	310
v	110	175	205	230	275	295	320	360
l	120	160	180	200	240	255	275	360
o	7	13	13	13	13	13	13	15
p	220	300	300	360	450	500	600	620
u	32	25	25	30	30	30	35	50
c	-	55	65	75	90	90	100	100
d	-	9.5	9.5	9.5	14	14	14	15
in/out BSP	3/8"	1/2"	3/4"	1"	1 1/4"	1 1/4"	1 1/2"	2"

* Dimensions in mm