

Gusher® 30

Largest Capacity Bilge Pump In The Whale Range

- Double action high capacity bilge pump
- Twin diaphragms mean high capacity, and ensures that pump continues working if one diaphragm is damaged
- No tools required for inspection or cleaning
- Available with a variety of mounting options including deck / floor, bulkhead or thru deck models
- Over 117 ltrs (31 US gals) per minute maximum output
- Corrosion resistant, powder-coated, die-cast aluminium alloy
- Nitrile valves and diaphragms will pump oily bilge water, effluent and diesel

Typical Uses

- Water ballast pump
- Emergency bilge pump out

Model Specifications

| Model Product Code | On Deck BP3000 | On Bulkhead BP3010 | Thru Deck Only BP3020 |
|---------------------------------|---|-----------------------|--------------------------|
| Hose Connections | 38 mm (1 1/2") Hose Connections | | |
| Weight | 5.05 kg (11.1 lbs) | | 5.9 kg (13 lbs) |
| Materials | Pump Body: Marine Grade LM6 Aluminium Alloy (epoxy coated) Diaphragm: Nitrile, Bushes: Acetal, Handwheels: Nylon Fasteners: Stainless Steel | | |
| Materials In Contact With Fluid | Marine Grade LM6 Aluminium Alloy (epoxy coated) Nitrile, Stainless Steel | | |
| Service Kit | AK3050 - Service Kit for Gusher® 30 Contains: Diaphragms, Valves, Gasket | | |
| Accessories | AS3020 - Thru Deck Conversion Kit (for BP3000) AS3095 - Spare Handle DP3804 Deckplate | | |
| Maximum Suction Lift | 4 m (13.5 ft) | | |
| Maximum Discharge Head | 4 m (13.5 ft) | | |

Performance Data

| | BP3000 / BP3010 BP3020 | BP3000 / BP3010 BP3020 | BP3000 / BP3010 BP3020 |
|-----------------------|---------------------------|---------------------------|---------------------------|
| Suction Lift | 0 | 1 m (3 ft) | 2 m (6 ft) |
| Discharge Head | 0.5 m (1.5 ft) | 0.5 m (1.5 ft) | 0.5 m (1.5 ft) |
| 45 Strokes per Minute | 75 ltrs (20 US gals) | 71 ltrs (19 US gals) | 71 ltrs (19 US gals) |
| 70 Strokes per Minute | 117 ltrs (31 US gals) | 111 ltrs (29 US gals) | 111 ltrs (29 US gals) |

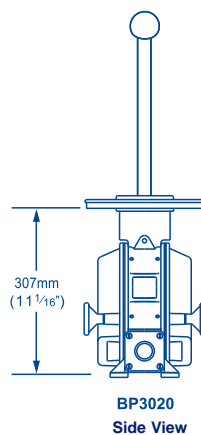
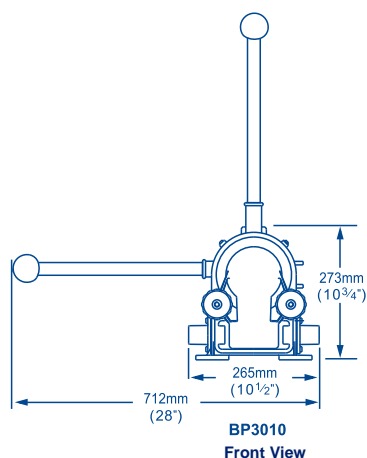
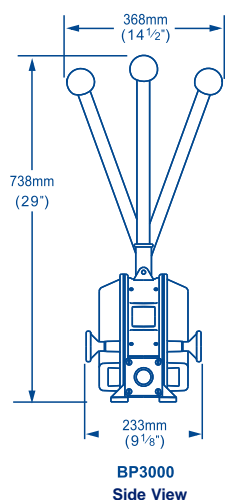

BP3000
Gusher® 30
5 Year Warranty